



The Trinity Amps

Triton

Amp Builder's Guide



**USAGE STRICTLY RESERVED FOR TRINITY AMPS CUSTOMERS
ONLY - PLEASE DO NOT DISTRIBUTE**

Version 21.5 Parts © Trinity Amps 2005 - 2021 www.trinityamps.com

Table of Contents

Introduction.....	5
Sources of help.....	5
Acknowledgements.....	5
WARNING.....	6
Please Read this Information Carefully.....	6
Version Control.....	7
Builders Guide General Theory.....	8
Circuit Description.....	8
Power Supply.....	8
Input / Preamp Stage.....	8
How Grid Leak Bias Works.....	8
Power / Output Stage.....	9
Triton Specifications.....	10
Building an Amp.....	11
Introduction.....	11
Switches and wire.....	11
Physical layout.....	11
Grounding.....	11
Insulated jacks.....	12
Minimizing transformer interference.....	12
Wiring.....	12
Assembling the amp.....	13
Before You Begin.....	13
Tools.....	13
Soldering.....	13
Tube Pin Numbering.....	14
Triton Build Tips.....	15
Assembly Steps Summary.....	16
Install Hardware.....	17
Wiring.....	17
Run Heater Wires.....	18
Install Power Transformer.....	19
Trinity Triton Grounding Scheme.....	20
Mains Power Connection.....	21
Wire the Rectifier Socket.....	23
Install the Output Transformer - Output Jacks.....	24
Impedance Switch.....	25
Install Preamp Ground Lug.....	26
Assemble the Eyelet Board.....	27
Install the Jumpers.....	27
Eyelet Board Components.....	27
Build the Eyelet Board.....	27
Mount the Board.....	30
Connecting the Board.....	30
Connect Board to Volume Control.....	31
Co-Axial Cable to Volume Control.....	33
Input Jacks.....	33

Final checkout	35
Power Up	36
Working Inside A Tube Amplifier Safely	36
Unplug.....	36
Sit.....	36
Drain.....	36
Test.....	36
Close	36
Making a Voltage Measurement	37
Discharging the Power Supply.....	37
Start Up	38
General Amplifier Operation.....	40
Some DO NOTS	40
Trinity Triton Voltage Chart	41
WARNING	42
Please Read this Information Carefully	42
Builders Guide General Troubleshooting	43
Tone Tweaking.....	43
Reducing Low End Response	43
Use 6L6 Output Tubes.....	43
Optional Grid Resistors	43
Input Grid Resistors	44
More Tips for fine tuning your amp.....	44
How to read Resistor Color Codes	45
How to read Capacitor Codes.....	46
FAQ	49
Triton Bill Of Materials (BOM).....	52
Trinity Amps Schematics and Layouts	54

Introduction

This guide has been prepared for builders of Trinity Amps Kits. It is always being improved and we would appreciate your feedback and comments to: stephen@trinityamps.com

Accordingly, content and specifications are subject to change without notice.

We do try to make it as accurate as possible, but it is sometimes hard to keep up with the changes. Therefore, if you do find an error, please let us know about it and we will correct it. Suggestions are welcome so if you have one, please get in touch with us.

Sources of help.

Forums: Please use the various forums to get help. They are an excellent resource and can be found at trinityamps.com Fender forum.

The Fender Amp Field Guide is a terrific resource for all amps Fender

Email: We can't help with every problem but if you can not get your problem resolved, email us and we'll do our best to help.

Phone Call: If your problem can't be solved, email for a phone appointment.

Acknowledgements

Much of the content in this document is original. Rather than reinvent content, some parts are based on content from other excellent sources and are hereby acknowledged.

R.G. Keen's site www.geofex.com - Tube Amp FAQ, Tube Amp Debugging

AX84.com site www.AX84.com - Gary Anwyl's P1 construction guide version 1.0

GM Arts website <http://users.chariot.net.au/~gmarts/index.html> - Guitar Amp Basics

Aron from diystompboxes.com

Parts © Trinity Amps 2005. No part of this document may be copied or reprinted without written permission of Trinity Amps or contributing authors listed above.

WARNING

Please Read this Information Carefully

The projects described in these pages utilize **POTENTIALLY FATAL HIGH VOLTAGES**. If you are in any way unfamiliar with high voltage circuits or are uncomfortable working around high voltages, **PLEASE DO NOT RISK YOUR LIFE BY BUILDING THEM**. Seek help from a competent technician before building any unfamiliar electronics circuit. While efforts are made to ensure accuracy of these circuits, no guarantee is provided, of any kind!

USE AT YOUR OWN RISK: TRINITY AMPS EXPRESSLY DISCLAIM ALL LIABILITY FOR INJURY OR PROPERTY DAMAGE RESULTING FROM THIS INFORMATION! ALL INFORMATION IS PROVIDED 'AS-IS' AND WITHOUT WARRANTY OF ANY KIND.

REMEMBER: NEVER OPERATE YOUR AMP WITHOUT A LOAD. YOU WILL RUIN YOUR OUTPUT TRANSFORMER!

Version Control

Version	Date	Change
1.0	4 Apr 17	Initial Draft issue
1.1	25Sep17	Initial Release
1.11	21Nov17	Corrected text on OT wiring section; Clarified impedance and bias switch installation; corrected BOM, 220K 2W was 22K (ref. Moody Jandhyala);
1.2	8Sep18	Updated Power Ground and Eyelet Board mounting and BOM
1.21	23Sep	Eyelet board layout corrected (D. Davis)
1.22	26Dec18	Added Triton Eyelet Board Pictorial Checklist
1.23	29Apr19	Changed eyelet board mounting to stand-offs; updated BOM
1.3	14Nov19	Updated for new Heyboer Power Transformer
1.4	14Dec19	Updated for build process improvements
1.5	18 Jan20	Added Triton Build Tips.
1.51	10Mar20	Updated IEC Socket installation.
1.52	29Aug20	Updated details on Bias DPDT Switch wiring
1.53	8Oct20	Corrected 120V wiring description only.
21.1	24Feb21	Update New Version
21.2	16Aug21	Removed stand-by switch in power up sequence.
21.5	3Sep21	Updated input/output jacks and impedance & bias switches

Builders Guide General Theory

For a discussion on Guitar Amp Basics and Tube Amp Theory, please refer to our support page document [Builders Guide General Theory](#)

Circuit Description

Below is a brief description of the Triton circuit and function of each stage.

Power Supply

This circuit takes in the AC line voltage, steps it up with a power transformer and uses 3 pairs of secondary tap locations to power the circuit, heat the tube filaments, and drive the 5Y3 rectifying tube. The rectifying tube contains a pair of vacuum diodes and the following capacitors help to rectify the signal close to DC voltage to drive the circuit.

Input / Preamp Stage

This circuit receives the incoming guitar signal and sends the signal into the first preamp.

Input jack 1 lets your full guitar signal through and is used for lower-output pickups like a Strat's. Input jack 2 tames the signal from higher-output pups like vintage humbuckers. But you can plug in safely on either one, depending on how dirty you want the amp to sound.

The first place your guitar gets amplified is in the 6SJ7 pentode. The 6SJ7 is a pretty gain-y tube with lots of output, and is capable of amplifying your guitar signal very accurately in this circuit; it does so unless you drive it into overdrive with a boost pedal of some sort.

How Grid Leak Bias Works

Notice how the Triton's preamp circuit uses a 6.8M resistor on the grid of the 6SJ7. This is called 'grid leak bias'. The 6SJ7 cathode is connected directly to ground with no cathode resistor and the 6SJ7 bias voltage is the voltage difference between the grid and cathode. This type of bias gets its bias voltage from grid current and the grid current is caused by space charge electrons hitting the grid. The negatively charged electrons give the grid a negative voltage. An input "grid leak stop" capacitor of 0.022uF is required to keep the electrons captured by the grid from leaking out through the grid stoppers and 1M input resistor. The grid current is forced to flow through a large 6.8M grid leak resistor

which causes a voltage drop with negative voltage on the grid that functions as the bias voltage.

The grid leak stop capacitor actually performs three functions: It ensures grid current flows through the 6.8M grid leak resistor; it acts as a grid current reservoir to stabilize bias voltage; and it acts as a high-pass filter to remove unneeded bass frequencies.

The components inside do lots of things, but one is to shape the equalization, taming the low end so it doesn't waste power trying to amplify frequencies it simply can't handle or that you can't hear. This is part of what gives this amp its tone as a very nicely focused amp.

The Volume knob removes a part of your signal when below 10, but lets it through totally unaffected when wide open.

There is a by-passable tone control. By default, it is IN CIRCUIT and you pull out the Tone knob to bypass the tone shaping circuit.

The tone circuit is a basic, low loss circuit with hi and low pass filtering allowing you to brighten or darken your tone to account for room acoustics or an instrument with no tone control.

The signal from 6SJ7 is much more than enough to push the 6V6 or 6L6 into overdrive where a lot of really cool stuff will go on.

Power / Output Stage

The power stage is composed of a single pentode in cathode bias, Class A

The transformer steps down the high voltage and steps up the low magnitude current. An 8 or 4 ohm speaker is connected to the transformer secondary to output the sound.

The signal gets amplified by the 6V6, and travels to your speaker. In addition to being amplified by the 6V6, your signal can also get compressed (sustain, at the cost of some definition), it'll get nice fat guitar-sounding harmonics, and will likely get into heavy dirt as you dial up.

The speaker is operated by a driver magnet made from an Aluminum Nickel Cobalt alloy known as AlNiCo. From these you typically get a very warm sound, with modest headroom before you start hearing distortion (but not the same as "dirt.") and compression. The hemp cone Tone Tubby holds together better than any speaker on the market so you will never lose definition in this application.

The tiny size of the circuit is very basic and not a lot of fancy stuff to affect the way the circuit responds to your guitar. This makes the Triton a musical and touch-responsive amp since the circuit is so friendly to your guitar.

This a very uncluttered circuit that yields excellent tone performance within the limits of the power supply, and will turn up to give you South Side Chicago blues, monster dirt, sustain, and pick dynamics worthy of the best of rock 'n' roll amps.

Triton Specifications

Channels: 1

Controls Ch.1: Volume

Power output: 5 Watts 6V6; 10 Watts 6L6

Preamp Tubes: 1-6SJ7

Power Tubes: 1 – 6V6 Class A (6L6 Optional)

Rectifier: 5Y3

Bias: Cathode

Choke: no

Speaker: 8 inch Tone Tubby Humboldt Alnico

Outputs: 1

Speaker Output: 4, 8 switched

Voltage Support: 115 V 60Hz – 240 V 50Hz

Weight: 112 Combo 15 lbs.

Dimensions: 1-8 Combo: 13” H x 14” W x 8.5” D

Speaker Model: Recommended Tone Tubby Alnico

Building an Amp

Warning: Do not attempt to build a guitar amp unless you know how to work safely with the dangerous voltages present in a tube amp. These voltages can exceed 700 volts.

Introduction

If you have purchased your Trinity Amp as a kit, this guide will help you build a tube guitar amplifier. It is oriented towards someone who knows a little about electronics but is new to do-it-yourself amps. It outlines a simple path to getting a quality amp build.

Switches and wire

Use standard UL approved switches with a 125V/3A rating for the Power and Standby switches. Use 20 or 22 gauge insulated solid wire with a 600V rating. It is good to get a variety of colors so you can color code your wiring.

Use 18 Gauge stranded for mains wiring.

Physical layout

Make sure the jacks, sockets and pots mounted along the edge won't interfere with parts mounted on the underside of the chassis. Imagine how chassis will be mounted in the cabinet and make sure there is enough clearance for the speaker and mounting brackets. Trinity amp chassis are laid out with serviceability and neatness in mind.

Grounding

It is recommended that you follow the layout provided with your Trinity Amp. It has been tested and has proven reliable. If you choose to deviate, consider the following information.

Amps traditionally use the chassis for signal ground. This is not the best choice since it can create ground loops and bad ground connections may develop over time. It is better to use star grounding in which all of the local grounds are collected at a single 'star ground' point. With star grounding there is only one connection between the chassis and signal ground.

Here are some rules for laying out a star ground. More information on grounding can be found in the Tube Amp FAQ and the Tech Info page of Aiken Amplification.

- (1) Connect the power transformer center tap directly to the negative terminal of the first power supply filter capacitor (cap) then run a separate wire from the negative terminal to the star ground point.
- (2) Collect the ground points of each tube and its associated resistors and capacitors to a local ground point that is not connected to the chassis. Run one wire to the star ground point from each collection.
- (3) Run exactly one wire from the star ground point to chassis.
- (4) Insulate the input and output jacks from the chassis.

The safety ground wire from the mains is separate from the signal ground. Run a wire from the AC ground to the chassis near where the AC power enters the chassis.

Insulated jacks

To insulate the input and output jacks either use plastic insulated jacks or metal jacks with insulating washers. Some people prefer the increased durability of metal jacks. Insulating a metal jack requires a shoulder washer with a 3/8 in. internal hole that fits a 1/2 in. panel hole.

Minimizing transformer interference

To minimize coupling between the power transformer and output transformer orient them so their plates are at right angles. If possible, place them at opposite ends of the chassis.

Keep the input stage wiring short and away from the output stages. This minimizes the possibility of oscillations caused by coupling of the output signal into the input.

Mount the grid resistors as physically close to the grid pins as possible.

Use a twisted pair of wires for the tube filament wiring. Route it away from AC lines and close to the chassis.

Wiring

The traditional method of constructing amps involved mounting the components on tag board or fiberboard. This is the technique that is used for Trinity Amplifiers and is the recommended approach for service and reliability.

Assembling the amp

Before You Begin

When you first receive your kit, remove all of the parts from the shipping box and place them on a well-lit, clean surface. Check all of the parts against the parts list and verify that you have everything before you begin. Contact us at once if you are missing anything, or if something appears to be damaged.

Tools

- * 25 Watt, pencil tip soldering iron
- * 60/40 rosin core solder (.032" dia)
- * wire stripper
- * wire cutter
- * needle nose pliers
- * screwdrivers (Philips, slot)
- * multi-meter with minimum 500V range

Use a stand for the soldering iron, a sponge to keep the tip clean, de-soldering wick material and clip leads. You should also have a multi-meter with at least 600V range, preferably 1000V and an audible continuity checker. Try to get a multi-meter that measures capacitance. This lets you verify the value of your components before you install them.

Soldering

Soldering is accomplished by heating the components to be soldered and allowing the molten solder to flow onto them. Do not try to melt solder on the tip of the iron and transfer it to the solder joint. It doesn't work.

Follow these steps when soldering:

- Use 60/40 rosin-core solder.
- Keep the tip of the soldering iron clean. If it's dirty, wipe it on a damp sponge to clean it.
- Set the temperature of your soldering iron to about 700F.
- Melt some solder on the tip of the iron. The molten solder helps to efficiently transfer heat from the soldering iron to the component leads.
- Make a good mechanical connection first, and then make a good solder joint.
- Heat the leads to be soldered by touching it with the tip of the iron.

- Touch the solder to the leads. The solder should flow onto the leads. Avoid breathing the fumes.
- Remove the soldering iron and allow the solder joint to cool.
- Note: Do not apply the tip of the soldering iron to the eyelet board any longer than it takes for the solder to flow.

The solder joint should be clean and shiny. If it is dull looking it may be a 'cold solder joint' which is not a good electrical connection. If a solder joint is suspect, heat it with the iron to reflow the solder.

Tube Pin Numbering

- V1 is the preamp tube. 6SJ7
- V2 is the 6V6 power tube
- V3 is the 5Y3 rectifier

The pins on a 9-pin tube socket are numbered 1 to 9 in a clockwise direction when viewed from the bottom. Note that there is a gap between pins 1 and 9.

The pins on an 8-pin tube socket are numbered 1 to 8 in a clockwise direction when viewed from the bottom. Note that there is a gap between pins 1 and 8.

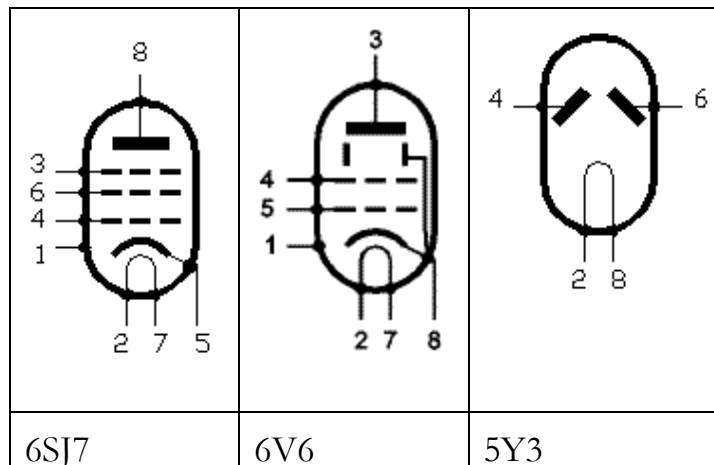
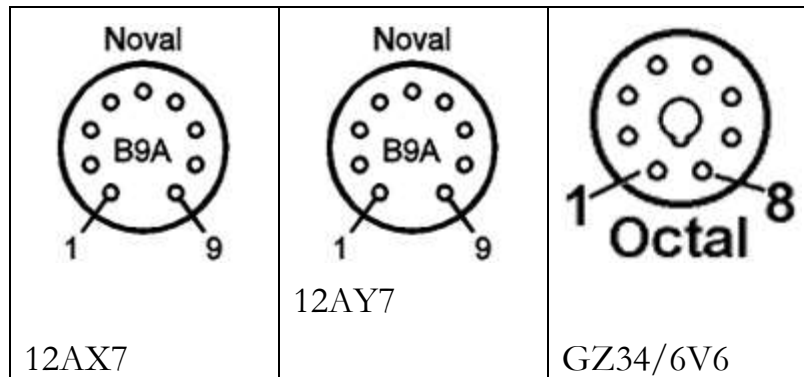

The pins on the potentiometers are numbered 1 to 3 from left to right when the shaft is facing towards you and the pins are at the top.

Triton Build Tips

Building the Triton is like building a ship in a bottle! Here are some tips that might help you.

1. You may want to pull all the leads out one hole of the power transformer. Remove the end bell, feed the leads through on hole. Reinstall the end bell.
2. Install the Mains ground lug and wire together before installing the IEC socket but don't solder to the IEC socket.
3. Orient the IEC socket ground lug so it points towards the rectifier tube socket.
4. Install the Preamp ground lug before installing the eyelet board. Attach two green wires that will connect to the eyelet board and the input jacks.
5. On the 6SJ7 socket, bend pins 1,3,5 inwards to facilitate connecting them together and to the ground wire going to the eyelet board.
6. Connect the LINE leads to the power transformer by passing the lead(s) through the IEC socket chassis hole and then orient the socket for easy socket access to soldering. Then install the IEC socket.
7. Orient the Pilot Light solder lugs pointing away from the transformer.
8. When possible, pre-solder wires to the DPDT switches before installing them. Insulate with shrink tubing as necessary.
9. Don't fully solder and fill the eyelets where there are wires to tube sockets or controls to be connected.
10. Try to minimize the primary voltage wiring by using switch lugs and IEC socket lugs to make the proper connections for your voltage.
11. Installing the Output Transformer is a tough job. An assistant can help. Run the head of the bolt from the inside into the nut on the outside. Don't tighten fully until all nuts are in place. Leave them loose so you can move the OT in order to let you get a nut in place. Then tighten solidly. Use some Lock-Tite if you want to make sure they never come loose.

Assembly Steps Summary

1. Install hardware on the Chassis.
2. Wire up the heater wires; connect to the pilot light.
3. Install Power Transformer and wire the Power Supply.
4. Install the Output Transformer; Wire to B+, output tube sockets and jacks
5. Assemble the eyelet board
6. Install the eyelet board.
7. Connect the eyelet board wires to power, sockets, and controls.
8. Wire and install input jacks. Connect to board.
9. Check components, wiring and connections.
- 10.** Follow Start-Up procedure.

Install Hardware

Install all the hardware on the chassis to make sure it all fits properly. Don't install the transformers yet.

Install all the tube sockets. The 8 pin sockets and clip retainers are for the 6V6 or 5Y3 tubes. The 6SJ7 does not use a retainer

The orientation of the sockets is as follows. Locate pin 1 of each socket and orient it so that pin 1 points away from the board. Fasten in place with screws into the 4-40 hole in the chassis using #4 screws. Nuts are not required. This orientation is done to slightly minimize the heater wiring and make connections to the board and transformer a little more convenient. See layout diagram.

Insert 2 grommets for wire leads passing through the chassis from the output transformer.

Ensure the potentiometer is located in the correct position. Cut off the locating tabs on the potentiometers in order to flush mount them. For the jacks you will need to use fibre washers to isolate them from the chassis. More on that later.

Install the #8 MAINS GROUND LUG and solder a 6" green line to it.

When you mount the IEC fused socket, orient the GROUND lug to give you clearance over the transformer.

The fused or LINE lug, is located at the end of the socket and the NON-FUSED or NEUTRAL is on the side.

When you mount the controls and pilot light and switches make sure that these components are tight and that if they come loose in the future they can't 'windmill' into each other and short out! The pots and input/output jacks must also be tight.

Install a DPDT Impedance Switch into the 1/4 inch hole located between the power tube and rectifier tube.

Install a DPDT Tube Selector Switch into the 1/4 inch hole located between the power tube and rectifier tube.

Wiring

Older amp designs were not grounded to the AC line, since most homes in the '50s only had two wire outlets. We ground the amp for safety. Power and preamp star grounding is used and the mains ground is bolted separately to the chassis. We run the individual pre-amp grounds directly to a separate star instead of 'bussing' them. This is done to reduce the background noise.

Here is a guideline for wiring the kits with the supplied wire:

- Use 22 gauge 600V solid for hook up to tubes
- Use 22 gauge 600V solid/stranded for hook up to pots/front panel
- Use 22 gauge 600V pre-twisted wire for tube heater wiring
- use 18 Gauge, stranded 600v for mains transformer primaries hook up.
- Re-use stranded cut offs from the transformers.

Run Heater Wires

Install the pilot lamp socket if you haven't already.

It is important to wire the tube filaments carefully. Use the Red-Black pre-twisted wire to do this. If you need to make up some heater wire, tightly twist two long lengths of wire tightly together. This will help to minimize any hum.

Follow the layout and Solder a Red and a Black wire to the indicator socket terminals

It is imperative that where possible, the signal wires run close to the chassis, while the heater wires run as far away from the signal wires as possible. Make sure the signal wires hug the chassis and the heaters have a tight twist on them. For the preamp, we have had success running the connection wires to them from as shown in the layout.

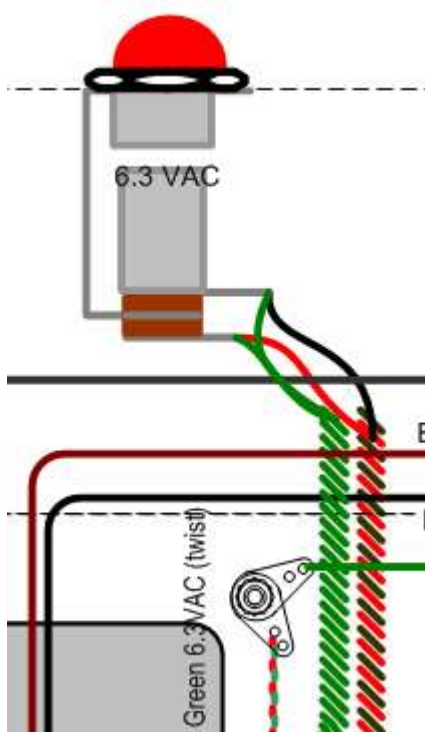

Note: Don't substitute smaller gauge heater wires. The wires need to be big enough to carry the current and keep hum low.

One wire comes from the indicator socket to the 6V6 Power Tube to pin 7, the other wire to same 6V6 Power Tube but pin 2.

Then these go to the preamp tube. Run the heater wires for the preamp as far away from the board as possible, along the inside of the chassis edge. One wire connects to pin 2 and 7 of the preamp tube

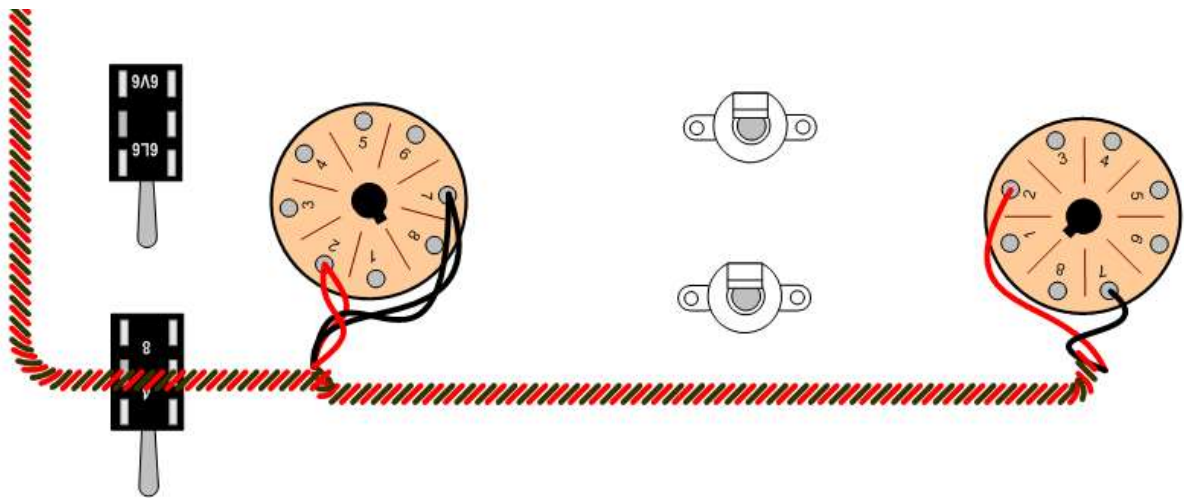

Once soldered, in place at each tube socket, press it flat, tight against the chassis.

Install Power Transformer

Orient the transformer with the chassis. Put the transformer in place and bolt it in place with the #8 nuts with washers as supplied. Put 2 #8 chassis lugs under the nut closest to the indicator lamp. This is the Power Ground. Tighten up the nuts.

TIP: if you remove the bell cover and route all the wires out one hole, installation may be easier.

If provided, you may also put 2 #6 chassis lugs held by a #6X3/8" Nut and Bolt in the hole just beside the transformer.. Tighten up the nuts.

Note: Leave the original transformer nuts in place so as to provide a gap between the transformer and chassis. This provides some heat and electrical isolation to the chassis.

Now, wire up the two 3.15VAC (6.3 VAC total) Green Leads from the power transformer and solder to the indicator socket lugs with the heater wires to the tubes.

Connect the Green-Yellow 0V 6.3V center tap wire to the Power Ground.

Then connect the High Voltage Red-Yellow 0V center tapped wire to the Power ground.

Solder the grounds in place to the Power Ground.

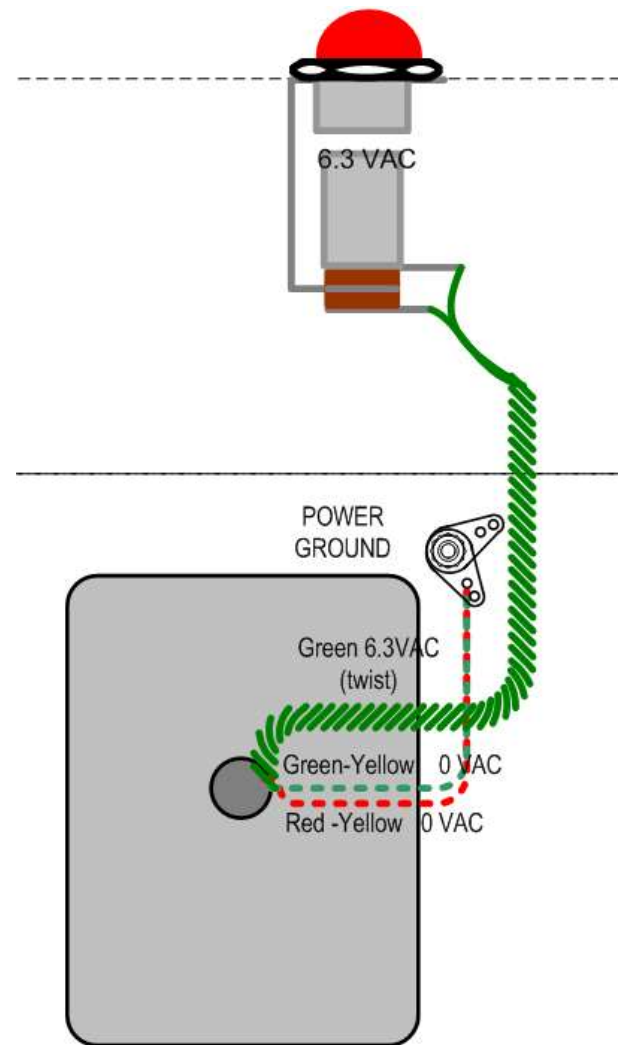

Trinity Triton Grounding Scheme

The Triton uses a two point grounding scheme where the High Current supply side of the amp is connected to a single common ground point, and the pre amp part is connected to another point on the chassis that is located immediately beside the input jacks.

Note: For grounding these amps, we strongly recommend that you follow the layout provided. We don't recommend that you deviate but if you do, use a collected one-point star grounding scheme. Everything connected together and marked with the 'earth' symbol on the schematic is connected together locally, and then that local common is connected to the star point.

Mains Power Connection

Wire up the rest of the main power supply.

Start at the IEC fused socket.

Before you install the IEC socket, attach the #8 Ground lug to the chassis immediately beside the socket and ensure it is grounded well. Tighten as much as possible with the #8 KEPS lock nut. Connect a green wire from the ground lug.

Install the IEC Socket.

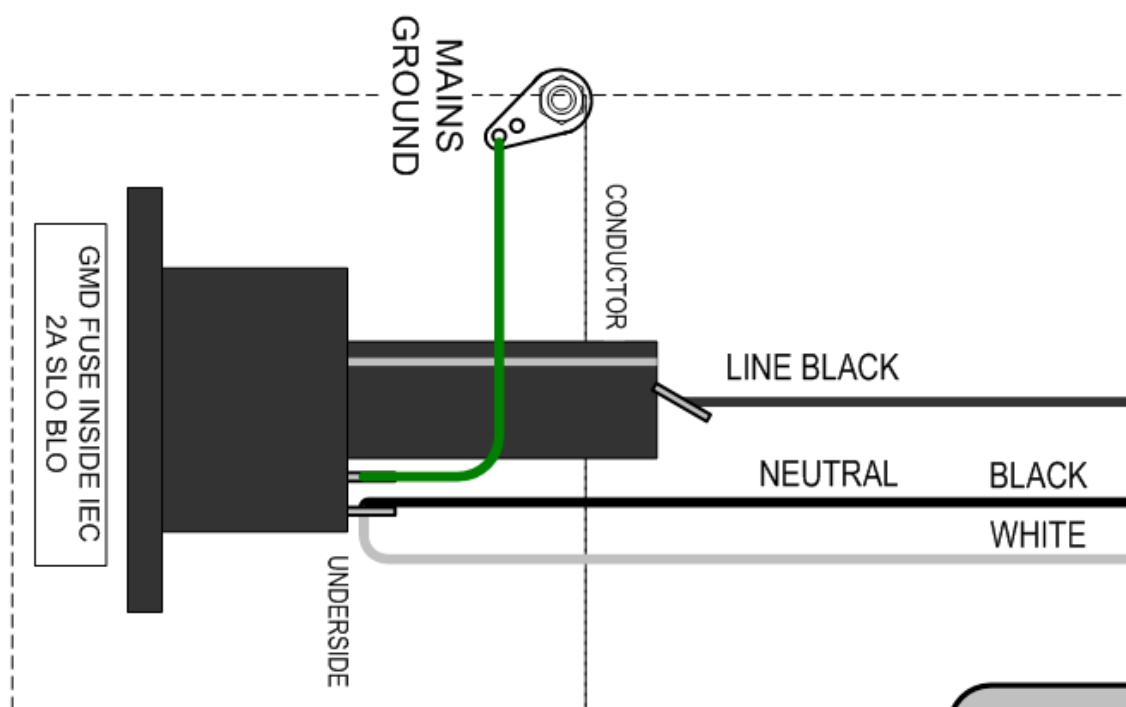

IMPORTANT NOTE: ALIGN THE IEC SOCKET SO THAT THE GROUND LUG FACES AWAY FROM THE MAINS GROUND LUG AND THE CONDUCTOR STRIP FACES UPWARDS.

Connect the MAINS GROUND WIRE to the IEC socket and GROUND LUG and solder.

120 VOLT WIRING: Connect a #18 Black/Hot line to the IEC socket.

IMPORTANT - Put a piece of heat shrink tubing over the Hot Line connection to double insulate it from touching the transformer housing.

Then connect the other end to the power switch. From the other side of the switch, connect to the transformer Black/Red – White/Red together for 120V input. Tie off the 100VC Black/White lead.

The Neutral side of the IEC fused socket is soldered to the ‘Common’ side of the power transformer and a piece of heat shrink tubing is put over it. For 120V, Twist the Black & White wires together and solder to the Neutral lug.

Tie off any unused taps that are not required for the Triton build. Tie it off by cutting off the exposed wire and then put heat-shrink over the end and then tuck it away as it is not used.

Triton HI CAPACITY Power Transformer Connection Schematic

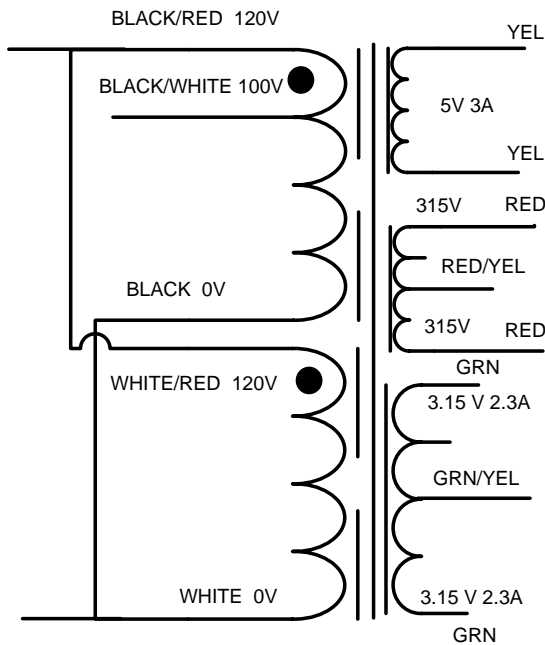

120V HOOK-UP

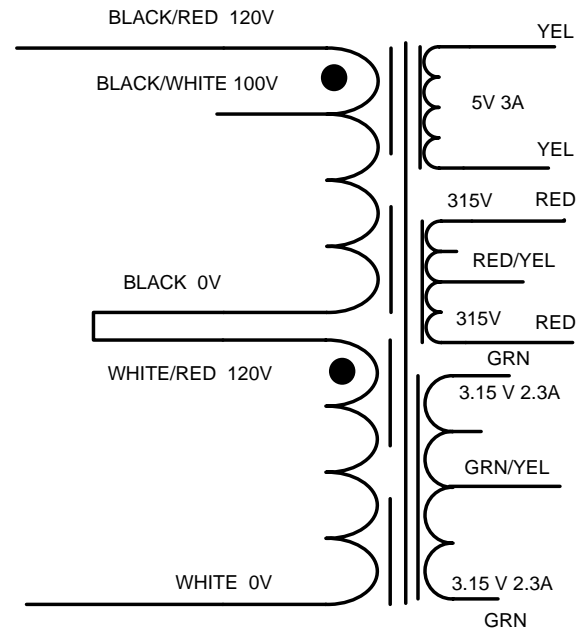

240V HOOK-UP

120V - use the primary in parallel hooking Black/Red to White/Red and Black to White. Connect 120 mains to Black/Red and White.

240V - use the primary in series hooking Black to White/Red. Connect 240 mains to Black/Red and White.

230V - connect 230V to Black/White and White wires and tie off the BLACK/RED wire.

Wire the Rectifier Socket

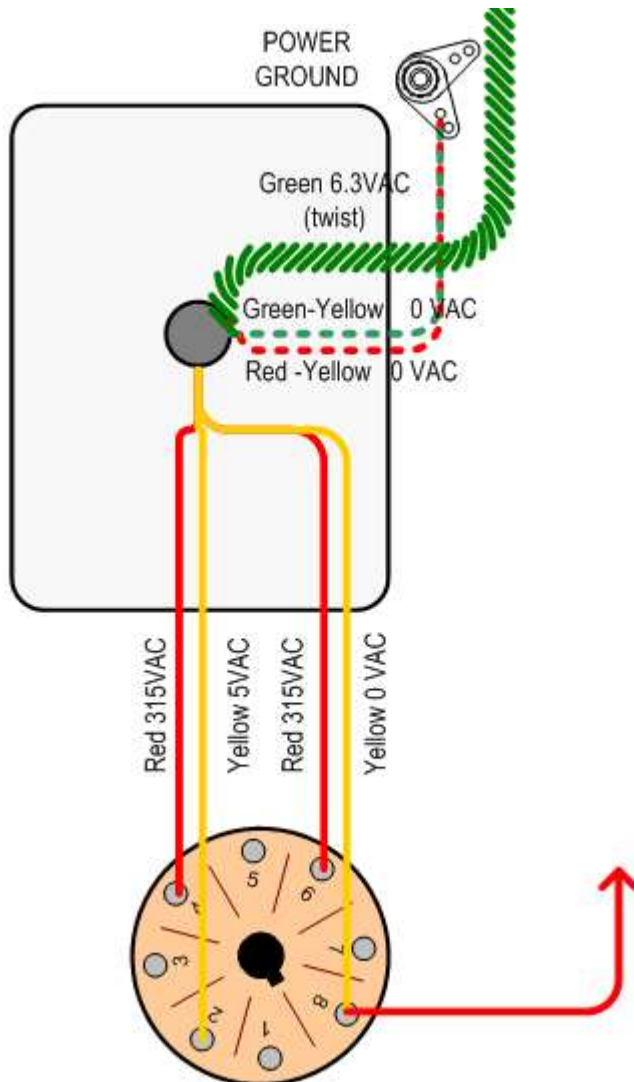

Twist the Power Transformer Yellow 5V Rectifier Heater wires together, cut to length and solder them to pins 2 and 8 of the rectifier socket. Connect a 6 inch red, 600V wire to pins 8 and solder at the socket end only.

Twist the Power Transformer Red 630V High Voltage wires together, cut to length and solder them to pins 4 and 6 of the rectifier socket.

Once you have wired up the transformer, IEC socket, rectifier socket, pilot light socket and heater wires, it is a good time to check that the Power transformer is working properly. Install a 2 AMP SLO BLO fuse inside the IEC Fused socket. There is a white cap that goes over the end of the fuse. Align the cap with the hole in the inside of the socket and use a small screwdriver to push it down into the socket and then turn it just enough and hold the cap and fuse in place.

and carefully apply power to the circuit (use a Variac if possible, or current limiting light bulb) and check that the AC voltages are within range of the spec. Note that they will be higher with NO tubes plugged in.

Install the Output Transformer - Output Jacks

Orient the Output Transformer so that the Yellow, Green and Black output (secondary wires) are closest to the output jack and Brown, Brown/Yellow (primary wires) closest to the Power tube. Feed all the leads through the previously installed plastic chassis grommets. Bolt the Output Transformer in place with four #6 - 3/8" bolts & KEPS nuts with the nuts on the outside of the chassis. Tighten.

Note: nuts on the outside of the chassis for eyelet board clearance.

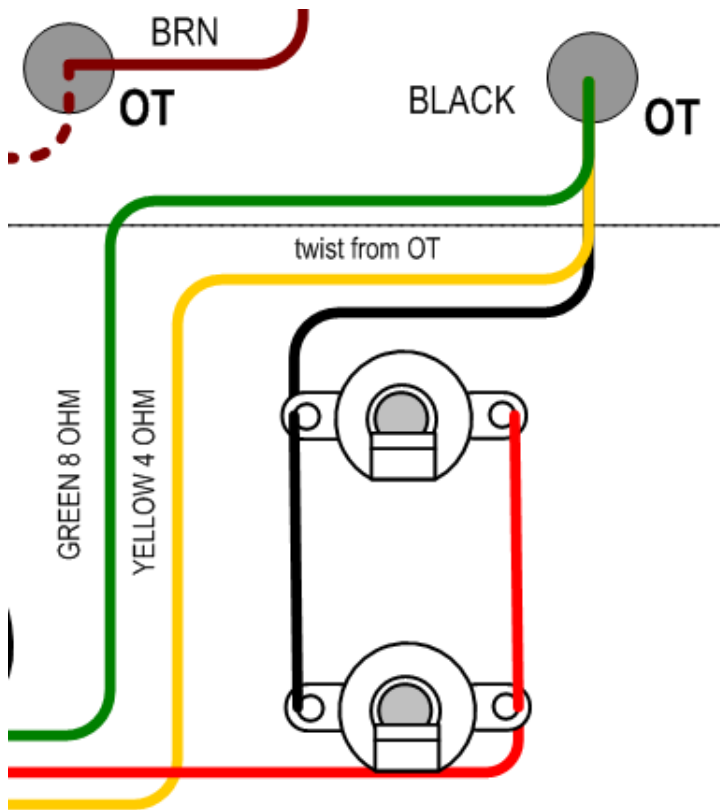

If not already installed, install the output jack 'connected' or grounded to the chassis. No fibre washers are used. Twist the output leads from the transformer to the output tubes.

Refer to the Output Transformer schematic.

The Primary leads from the transformer should be twisted together and the Secondary leads braided and both fed through the two chassis grommets.

Note: The Orange 16 ohm tap is not used in a standard Triton build so tie it off and tuck it away outside the

chassis.

Start by soldering the Brown/Yellow output lead to V2 pin 3. Eventually the Brown lead will get soldered to the board. See the Output Transformer schematic and wire up the output jack Black lead to the grounded side of the output jack.

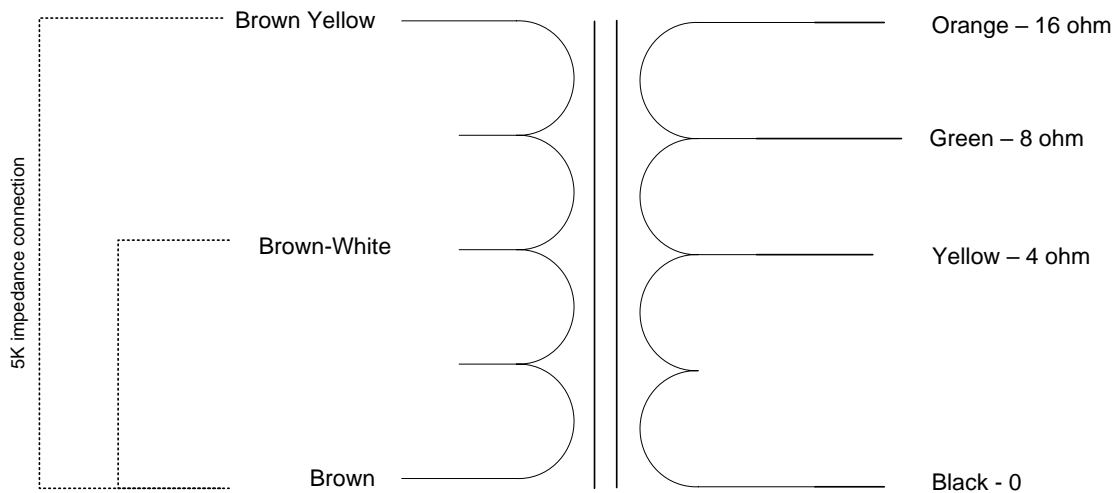

Impedance Switch

Cut a wire long enough to route from the Impedance DPDT switch center pole terminals to the output jack ‘tip’ lug. Hook a wire into the center pole of the switch and solder it in place. Solder the other end to the output jack. In this case, the positive or “Tip” end.

Neatly route and solder in place the 4 ohm, YELLOW lead, to one side of the DPDT Switch, both terminals. Neatly route and solder in place the 8 ohm, GREEN lead, to the other pole of the switch.

Connect the black Output Transformer lead to the other speaker jack. Connect the other output jack with another piece of wire making sure they’re connected to the same jack terminals. In this case, the negative or ”Ring” end.

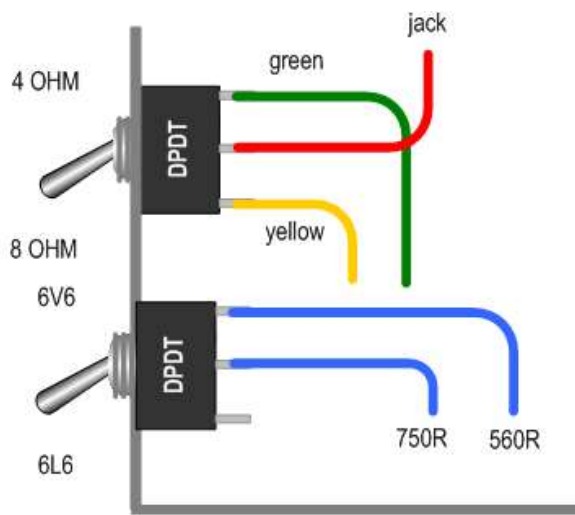
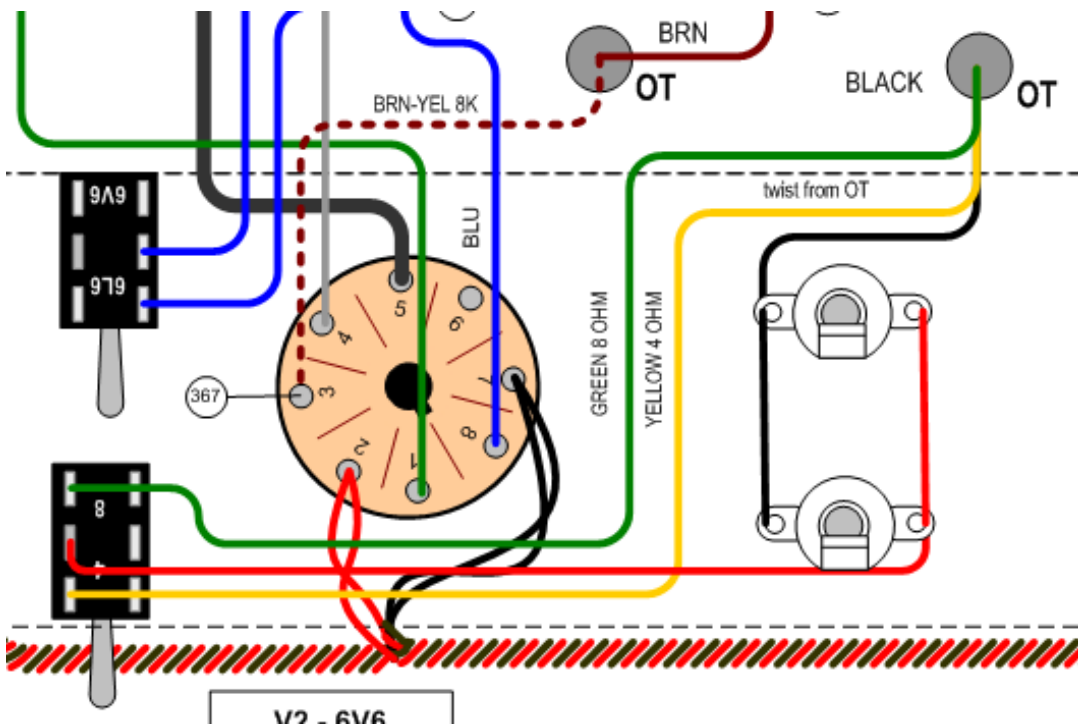

Side View of Switches

Align the toggle switch on the chassis so the impedance settings match the chassis lettering.

Note: You may choose to only wire the 8 ohm only. If the 4 ohm is not to be used omit the impedance switch and hard wire the 8 ohm GREEN lead to the speaker jacks and then the put some shrink tubing over the end of the YELLOW lead.

Install Preamp Ground Lug

Install a #4 GROUND LUG using bolt and nut and #4 chassis lug, in the #4 hole close to the input jacks. Run 3 6" green wires from the ground lug. Solder at the lug end.

Assemble the Eyelet Board

If you do not have a pre-built Trinity amps eyelet board, now is the time to build it.

Install the Jumpers

Install the jumper wires on the topside of the board. These are the dotted lines on the supplied layout diagram. Follow the pictures below and the layout. Do not solder in place yet.

Eyelet Board Components

Align the board according to the layout diagram and follow the diagram closely as you build the board.

Carefully identify all the board components and their values. **Measure those that you can to confirm the values.** See the section on how to read Resistor and Capacitor codes.

When installing Electrolytic Capacitors (power supply, bypass caps), ensure that they are aligned with the correct polarity on the board. There may be a '+' sign, or indentation to identify the positive end of the capacitor or arrows pointing to the negative (ground) end of an electrolytic capacitor. Usually, capacitors with values less than 1uF have no polarity requirements or markings.

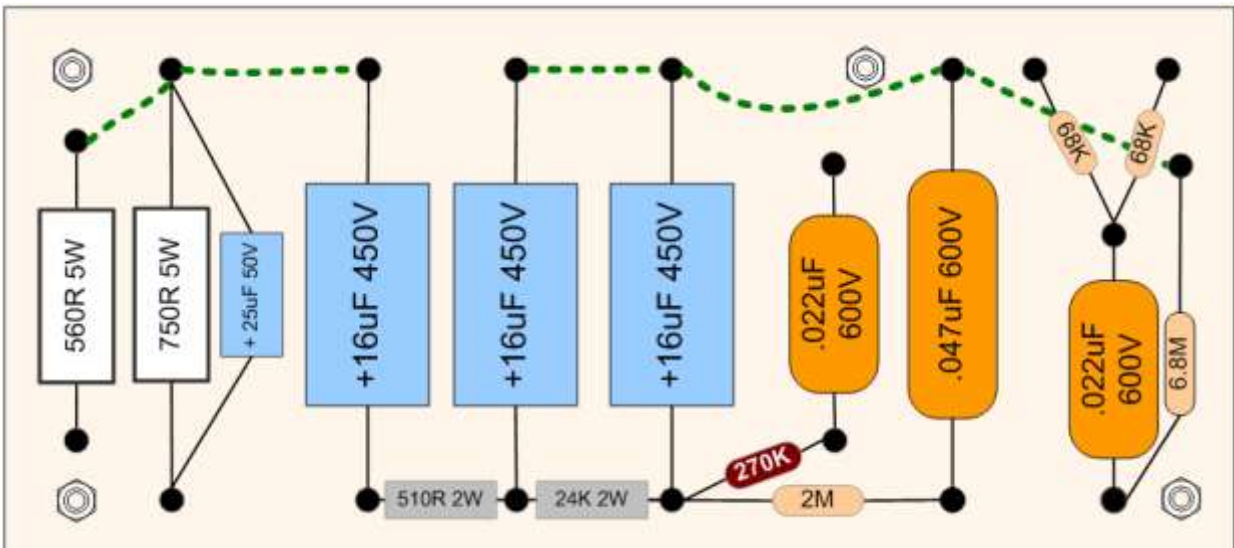

Build the Eyelet Board

Install the components on the board by following the layout from left to right.

NOTE: be extremely careful to trim the leads tight to the bottom of the board as there is only 1/4" clearance from bottom of board to steel chassis.

Any leads touching the chassis could cause a short circuit and possible electrocution!!!

Start with the larger parts on the power supply side of the board. Then, work your way over to the signal components. Make all of your connections as neatly as possible. At each eyelet, mount and solder ALL of the components including the flying leads that belong in each eyelet and solder once.

Crimp all wires tightly at the connection point before soldering. Remember, your solder joints should be bright and shiny. Double check all of your connections for shorts against adjoining components or terminal posts.

Flying leads are also installed at this time. Cut connecting wires in various colors and about 6" long (rear) and 8" long (front). Following the layout, install the connecting wires to the board leaving plenty of extra length, wire is not expensive and it'll save aggravation later

Start with the 560R 5 Watt resistor, then the 750R 5W/25uF cathode pair.

Note: Make sure the 750R/25uF cathode pair are separated slightly from each other and the board as they emit some heat. Install flying leads and solder in place

Move on to the 3 - 16uF 500V filter capacitors and power supply resistors.

Continue with the remaining parts, following the layout provided.

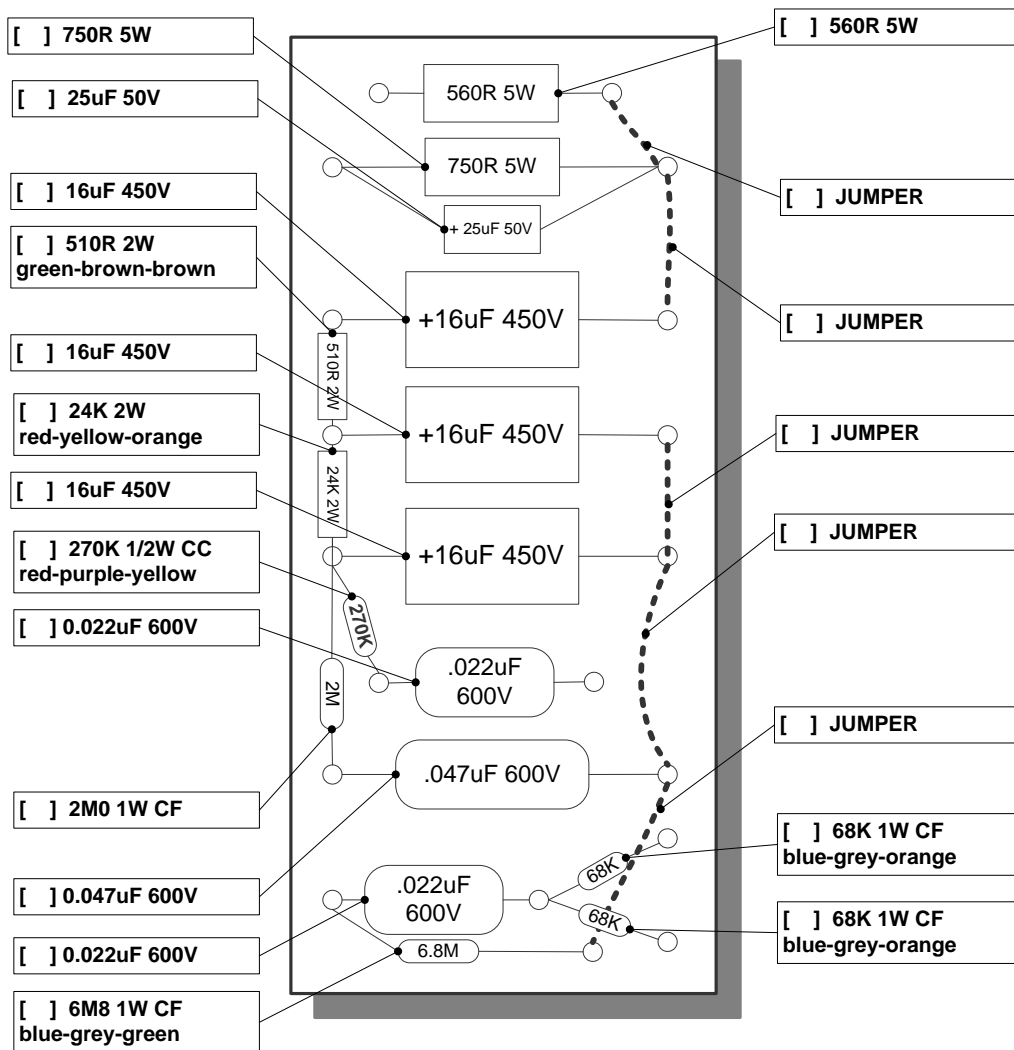

TRITON EYELET BOARD PICTORIAL CHECKLIST

Note: For multiple component leads that must fit into one eyelet or eyelet, insert them first and solder once when they are all in place. Bend each component lead at 90 degrees so that it fits into the eyelet squarely and neatly. Solder each eyelet once all component leads that connect to it, jumpers and flying leads are in place.

Tip: Check off each parts on the pictorial checklist as you complete each connection to that point to track progress and confirm that all parts are in the correct orientation and position. It's well worth the time to re-check the eyelet board layout before installing it in the chassis.

As you proceed, closely trim any excess wire and solder off on the underside of the board. **NOTE:** *be extremely careful to trim the leads tight to the bottom of the board as there is only 1/4" clearance from bottom of board to steel chassis. Any leads touching the chassis could cause a short circuit and possible electrocution!!!*

Mount the Board

The 'point to point' eyelet board is mounted by #6 X 1/2" screws and "sandwiches" 1/4" long nylon standoffs between the eyelet board and the chassis. This is done to provide clearance in a tight space. E.g. HI Input jack clearance.

Align the holes in both board, (a toothpick is handy here!) stand-off and the chassis and screw them together from the inside through the eyelet board and through the stand-off board. For convenience, the holes for the #6 screws are threaded in the chassis. Put a lock-washer under the heads of the screws.

Nuts are not required

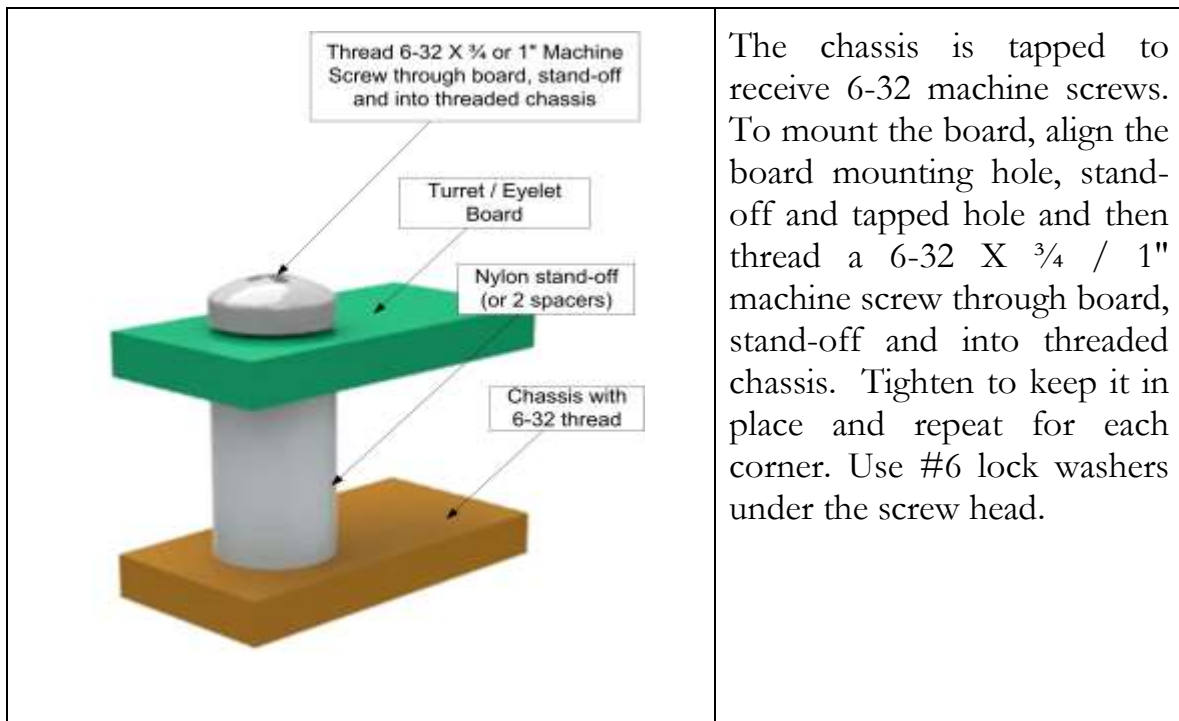

Connecting the Board

Now is the time to make the connections from the eyelet board to the tubes and potentiometers.

Tip: On a photocopy of the layout, highlight the connections as you complete them to make sure they are done correctly.

1. Connect and solder the power wire from the rectifier pin 8 to the 510R / first 16uF connection on the board.

2. Connect and solder the Output Transformer Brown tap to the intersection of the 510R 2W / 24K 2W lead on the board
3. Connect and solder the ground wire from the ground side of the 560R cathode resistor pair to the Power Ground. (Ground wire attached in previous step)
4. **Bias DPDT Switch** - Connect and solder the **Bias DPDT Switch** center pole terminals to the 560R 5W 6V6 cathode bias resistor lead. Hook a wire into the outside pole of the bias switch and solder it in place on the 750R 5W 6L6 cathode bias resistor lead.
5. Connect and solder the lead from the 750R 5W 6V6 cathode bias resistor to the power tube socket, pin8.

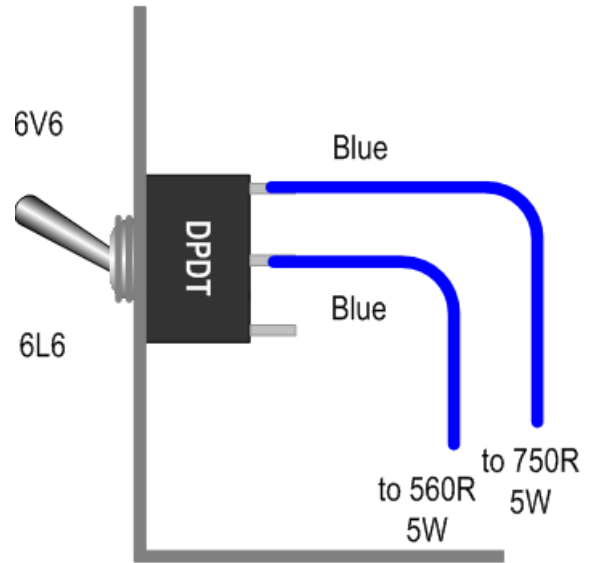

Side View of Tube Bias Switch

Align the toggle switch on the chassis so the tube bias settings match the chassis lettering.

6. Connect and solder the ground wire from the ground side of the 6M8 ohm preamp tube resistor to the Pre-Amp Ground. (ground wire attached in previous step)

Then start at one end of the board and work your way sequentially around the board doing the point-to-point wiring with the flying leads to tube sockets. Board to tube pin; board to tube pin etc. Start at V1, pin 1 and move to the far end of the board to V2.

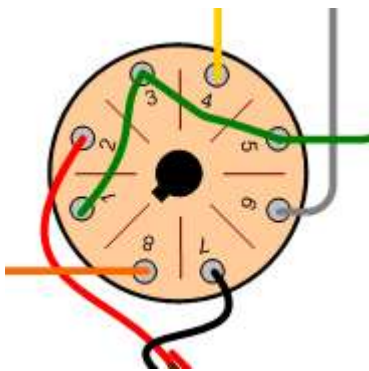

On V1, that the ground wire connects to pins 1, 3, 5 and then goes to ground. These wires must be insulated from all other pins on V1.

Connect Board to Volume Control

The easiest way to wire these correctly is to carefully follow the layout, and do one terminal connection at a time.

Run a wire from the .022uF cap n the board to the centre-right terminal of the Tone switch and then another piece to the right terminal of the volume control. Solder in place.

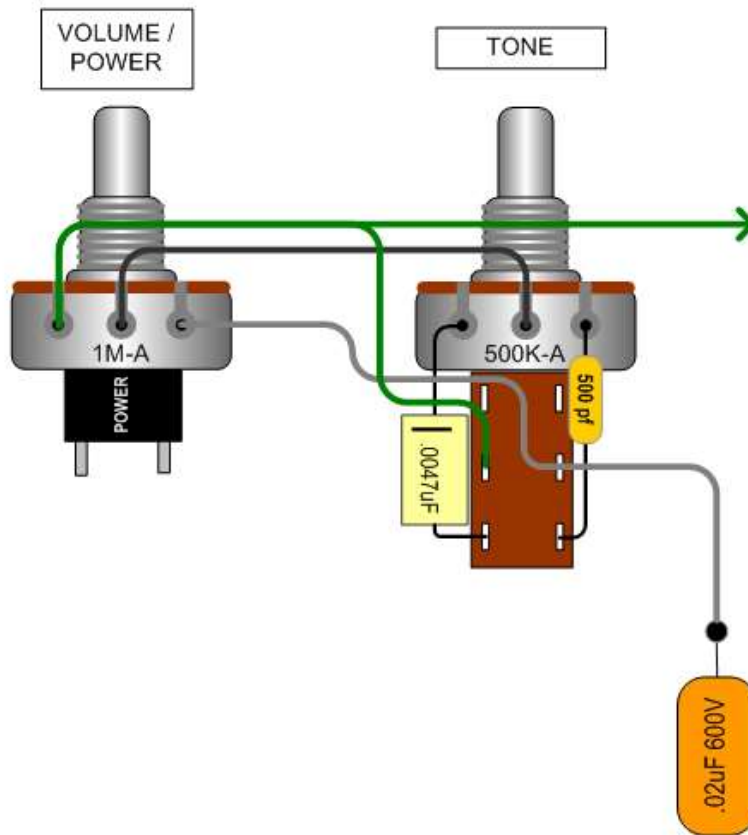

Connect a green ground wire from the centre-left terminal of the Tone switch to the volume Control left terminal. Solder at Tone Switch. Connect another 6" green flying lead ground wire to the volume Control left terminal. Solder at the Volume control end only.

Connect a .0047uf cap between the left-bottom terminal of the Tone switch and the left terminal of the Tone control.

Connect a 500pf cap between the right-bottom terminal of the Tone switch and the right terminal of the Tone control.

Connect the centre terminals of the Volume Control and the Tone control together.

Co-Axial Cable to Volume Control

This is done to reduce noise. To prepare the co-axial cable for connections:

1. Cut back the outside plastic covering at both ends by about 5/8" to reveal the braided shield.
2. At one end, pull back the shield and cut it off at the 5/8" mark. Put some heat shrink around the end covering the area where it was cut off.
3. At the other end, pull back the shield but poke a very fine screwdriver or pick into the shield and work out a 'hole'. Fish the inside conductor through this hole and pull it through.
4. Twist the braid together.
5. Finally, cut back the outside plastic covering on the inside conductor at both ends by about 1/4"

Follow the layout provided and connect the centre of the co-ax cable to the centre Volume control potentiometer lug and the co-ax shield to Ground, left side. Be sure to ground only at this end of the cable.

Connect the centre core wire of the other end to V2, pin 5.

Route one of the green wires from the ground lug to the VOLUME CONTROL left terminal. Solder at the Volume control lug end.

Input Jacks

To wire up the input jacks, it is easiest to remove the jacks from the chassis and set the spacing per channel pair correctly to match the chassis. Some people like to temporarily install them on the 'outside' of the chassis to get the spacing correct, wire them up, then remove and install them on the inside. Remember to ensure they are oriented so they do not interfere with the eyelet board.

Pay attention to the HI input jack interfering with the eyelet board and align accordingly.

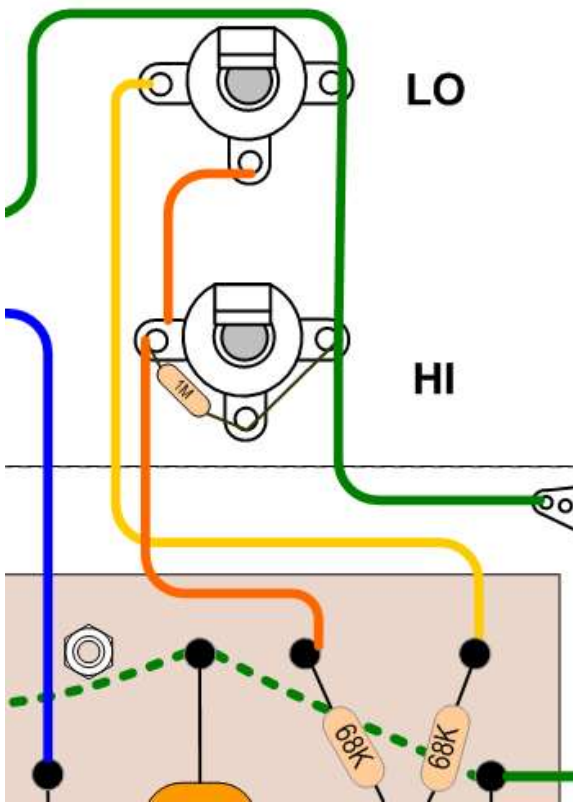

Wire the input jacks with the 1M Carbon Film resistor and jumpers and then reinstall them.

Leave enough flying lead wire for the ground wires on the input jacks go to the pre-amp ground and about 6" to reach the board from each jack.

Use solid some core wire from the input jacks to the eyelet board.

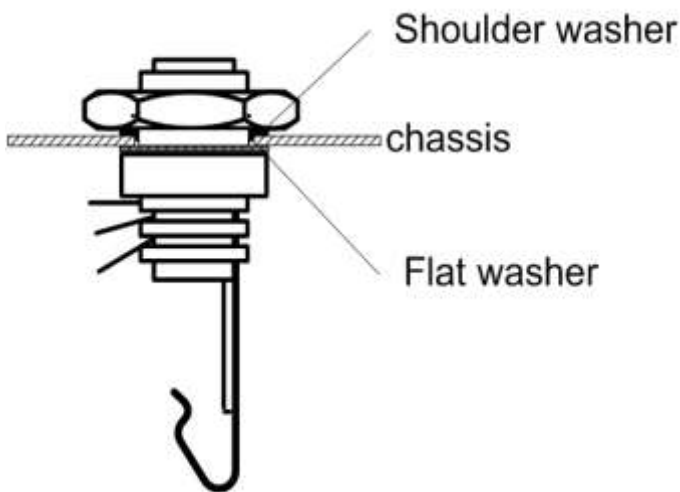

Install the Switchcraft switched input jacks. Use the supplied black shoulder washers and flat washers to insulate the jack from the chassis. This is necessary for noise reduction. Refer to the diagram and install the washers with the shoulder of the outside inserted into the chassis. The rear washer has no shoulder and they are sandwiched in place by the jack and mounting nut. Tighten securely. Once installed, test to confirm that there is no electrical connection from the jack to chassis.

Then connect and solder the leads to GROUND tag and input leads to the 2-68K input grid resistors on the board.

Final checkout

When you finish assembling the amp, double-check the wiring and the components. Trace or highlight the connections on a copy of the layout provided with the amp to ensure the amp is wired correctly. Check everything at least once!

Measure the resistance from each part that has a GROUND connection to the chassis. Put your probe on the parts lead. All readings should be less than 1 ohm, typically 0.5 ohms.

Make sure the Mains GROUND at the chassis is **very** tight.

Power Up

SAFETY WARNING READ THIS FIRST!!!!

Working Inside A Tube Amplifier Safely

Working inside a tube amplifier can be dangerous if you don't know the basic safety practices. If you aren't prepared to take the time to learn and apply the right precautions to keep yourself safe, don't work on your own amp. You can seriously injure yourself or get yourself killed.

Unplug Pretty self explanatory. Do not, ever, ever, leave the equipment plugged in and start work on it. Leaving it plugged in guarantees that you will have hazardous voltages inside the chassis where you are about to work.

Sit If the amp has been turned on recently, the caps will still have some high voltage left in them after the switch is turned off. Let it sit for five minutes after you turn it off.

Drain When you open up an amp, you need to find a way to drain off any residual high voltage. A handy way to do this is to connect a shorting jumper between the plate of a preamp tube and chassis ground. This jumper will drain any high voltage to ground through the 50k to 100K 2W plate resistor on the tube. To do this successfully, you will need to know which pins are the plate pins. Look it up for the amp you're going to be working on. You'll need to know this for the work anyway. Leave the jumper in place while you do your work. Remember to remove it when you finish your work. You can also permanently install a 220K 2W resistor on the B+ line to chassis ground to do this.

Test Take your multimeter and ground the negative, black lead to the chassis. With the positive, red lead, probe the high voltage cap terminals or leads and be sure the voltage across them is low. Preferably to less than 10V.

Close First take the shorting jumper out. Put the chassis back in the cabinet, making sure all of your tools, stray bits of solder, wire, etc. are out of it. You don't have to actually put all the screws and so forth back in if you believe more work might be needed, but make sure that the chassis is sitting stably in the cabinet and won't fall out.

First note that most meters have three input jacks (some have four) one is marked COM, the BLACK lead goes there. Another jack is marked V, ohm, mA, the RED lead goes there for most measurements. The third jack is a high current jack usually marked 10ADC (sometimes it is 20 or some other number). This jack is used only for high current measurements. The four jack models use separate jacks for current measurements, this makes accidentally setting the meter to a

current mode harder, but it still can be set to resistance. For vacuum tube electronics we can usually ignore the high current mode. Put your test leads into the COM and V(ohm)mA jacks and leave them there.

Making a Voltage Measurement

Before attempting to make a voltage measurement, think about the anticipated result.

- Is this a DC or AC voltage?
- How much voltage will be present?
- If things are not working correctly what is the highest voltage that I might find?

A voltage is ALWAYS measured between TWO points. Is one of those points CHASSIS GROUND? This is the most common case. If not, can you make a different measurement such that one of the measurement points IS GROUND? If your measurements are all referenced to CHASSIS GROUND, you can then connect the black lead (Negative or Common) to the CHASSIS with a clip and probe the other test point with the RED (Positive) lead.

1. Set the selector switch on the meter to the range that is higher than the maximum anticipated voltage of the appropriate type (DC or AC). If the maximum anticipated voltage is not known, set the meter to the highest range available.
2. Wherever possible connect the meter into the circuit when the circuit is OFF, then power up the circuit without touching anything.
3. Read the meter. If the reading is lower than the next available lower range on the meter you may set the meter to a lower range while the circuit is on. When doing this touch ONLY the meter with ONE hand, and be careful to only lower the meter one range, allow the readings to stabilize (2 or 3 seconds) before proceeding further.

Note: Accidentally setting the meter to a current or resistance range can damage the meter, and the circuit it is connected to. If the circuit has sufficient power the meter can explode or burst into flames. I know from experience that this will happen if you try to measure the resistance of the wall outlet. Most modern meters are "fuse and diode protected" this is to prevent fireworks, but will not usually save the meter from an overload of this magnitude.

Discharging the Power Supply

If you need to service the amp after having it on, you must “discharge” the power supply capacitors. This is done by unplugging the amp, turning the power to the on position and letting it sit for 60 seconds or so. The 220K 2W resistor

will drain the supply in 60 seconds but always use a multimeter to check the residual B+ voltage in the large filter capacitors to make sure it is fully discharged.

REMEMBER: DO NOT OPERATE YOUR AMP WITHOUT A LOAD

Start Up

Install a 2 AMP SLO BLO fuse inside the IEC Fused socket. There is a white cap that goes over the end of the fuse. Align the cap with the hole in the inside of the socket and use a small screwdriver to push it down into the socket and then turn it just enough and hold the cap and fuse in place.

Note: If you see or smell smoke when you turn on the amp, turn it off immediately and re-check the connections.

1. **With no rectifier in place**, apply power and test the High voltage AC and ensure that it is on the correct pins of the rectifier (pins 4 & 6) and in the correct voltage range (greater than 630 Volts AC across pins 4 & 6).
2. Test the filament voltages and ensure they are on the correct pins for all tubes.
3. 5 VAC across pins 2 and 8 or V3, 5Y3 Rectifier.
4. 6.3 VAC across pins 2 and 7 on V2 6V6 Power Tube
5. 6.3 VAC across pins 2 and 7 on V1 6SJ7 Pre-Amp Tubes
6. If all is OK, then shut off, **install the rectifier and apply power without the preamp or power tube installed**. Turn on the Power switch on the Triton. Check the plate voltages on the tube sockets. The plate voltages will be higher than the voltages listed on the schematic because there is no load provided by the tubes. It will be in excess of 400 Volts DC.
7. If everything is okay, power off the amp, install the 6SJ7 and 6V6 power tube, turn the volume to minimum and connect a speaker and power on again.
8. Measure the DC voltages from tube pin to chassis ground and compare to the layout, schematic or Trinity Triton Voltage Chart.

Tube	Plate Pin(s)	Cathode Pin(s)	Heater (pins)
V1 – 6SJ7	8	5	2, 7
V2 - 6V6	3	8	2, 7
V3 – 5Y3			2, 8

9. If the voltages seem close to the chart, then with volume setting at minimum and NO instrument plugged in, power up again. Listen for sounds that may indicate a problem. Loud transformer vibrations or humming or other crackling sounds. Observe if any of the components besides the tubes are getting hot – check the power resistors. Carefully check and make note of the voltages on all the tubes.
10. If all seems in order, and the fuse has not blown, turn the volume up a bit. If everything seems fine, plug in a cable, and touch one end. You should get a loud hum, this is a good sign. If you get this far, it's time to plug in your guitar and take the amp for a test run.
11. Hopefully, there are no problems but if you think there are e.g. hum, squeal etc., then move on to the troubleshooting section of this manual.

General Amplifier Operation

Some DO NOTS

- Never, Never, Never run the amp without a speaker plugged in. This can cause major Output Transformer damage.
- Do not flip the power switch off, and then back on rapidly. This can cause power supply damage.
- Never replace a burned out fuse with a bigger-amperage one. Remember - there was a reason the first one burned out, usually protecting something more expensive. Putting a bigger fuse in will just ratchet up the power level until something really vital burns out. If the second equal-rating fuse pops, turn it off and get a tech to look at it.
- Never ignore signs of high heat inside - a wisp of smoke or a burning smell is **NOT** normal.
- Your amp produces lots of heat, and will continue to do so even if you block the fresh air vents. Blocking the vents will overheat the amp and you may have to get some very expensive repairs done.
- Never ignore a red glow other than the small orange ends of the filaments. A red glow over a large part of the internal plates of the output tubes means they're about to melt. If you notice this, shut it down and get a tech to help you find out what it wrong.
-

Some DOs

- Add another speaker into the "external speaker" jack; a mismatched speaker load won't kill it, while an open circuit (disconnected speakers) may do so.

Note that in the long term, unless you have an impedance switch, the impedances should be matched to the OT , as in this case of the Triton , 8 ohms, or 2 16s in parallel.

- Overdrive the stuff out of it. Tubes are very forgiving of massive overdrives, unlike solid state stuff. As long as they tubes don't overheat or stay overdriven for long periods, it's not fatal.
- Overdrive the stuff out of it. Tubes are very fo
- rgiving of massive overdrives, unlike solid state stuff. As long as they tubes don't overheat or stay overdriven for long periods, it's not fatal.

Trinity Triton Voltage Chart

Measured voltages for Thomas de Leeuw Chassis Ser. 1912

AC Mains Voltage	120 VAC
B+ No tubes installed	420 VDC
B+ All tubes installed	387 VDC WITH JJ 5Y3

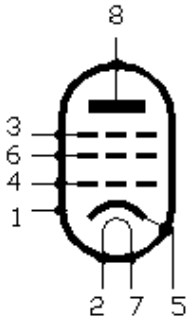
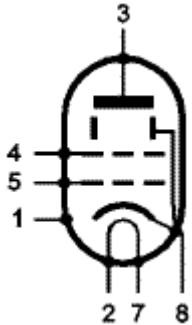
TUBE	Pin 1	Pin 2	Pin 3	Pin 4	Pin 5	Pin 6	Pin 7	Pin 8
V1 6SJ7 	--	--	0	-0.8	--	21	--	136
V2 6V6 		--	368	330			--	22.7

THE ABOVE DC VOLTAGES ARE MEASURED FROM TUBE PIN TO CHASSIS GROUND

WARNING

Please Read this Information Carefully

The projects described in these pages utilize **POTENTIALLY FATAL HIGH VOLTAGES**. If you are in any way unfamiliar with high voltage circuits or are uncomfortable working around high voltages, **PLEASE DO NOT RISK YOUR LIFE BY BUILDING THEM**. Seek help from a competent technician before building any unfamiliar electronics circuit. While efforts are made to ensure accuracy of these circuits, no guarantee is provided, of any kind!

USE AT YOUR OWN RISK: TRINITY AMPS EXPRESSLY DISCLAIM ALL LIABILITY FOR INJURY OR PROPERTY DAMAGE RESULTING FROM THIS INFORMATION! ALL INFORMATION IS PROVIDED 'AS-IS' AND WITHOUT WARRANTY OF ANY KIND.

Builders Guide General Troubleshooting

For a discussion on Guitar Amp Troubleshooting, please refer to our support page document [Builders Guide General Troubleshooting](#)

Tone Tweaking

Below are some modifications you might choose to implement in order to change the tone and response of your Trinity Triton. There are several Fender interest groups on the Internet who can provide some direction.

Reducing Low End Response

Change the 1st coupling cap from .022uF to .01uF to reduce the low end response [boominess].

You can reduce the 0.022uF coupling caps between the pre-amp and the power tube from 0.022F to 0.01uF

Use 6L6 Output Tubes

Install a 6L6 power tube and then switch the Bias switch to 6L6 position.

Optional Grid Resistors

If you look at a schematic of a typical guitar amplifier, you may notice that there is a resistor in series with the grid of the power tube, usually 1.5K or 5.6K yet some amplifiers have no such grid resistors and may not require them. These resistors, which are commonly called "grid stoppers". They act as a very high frequency low-pass filter. Attenuation only occurs at the higher frequencies, above the frequency breakpoint caused by the series resistance and the tube's input capacitance.

The Triton does not typically require them but if you notice any of the following symptoms, the grid resistor can accomplish the following things:

- help prevent high frequency parasitic oscillation in the tube itself;
- help prevent radio frequencies from getting into the input stage, where they can be rectified and low pass filtered (AM detection) and become audible at the amplifier output; and
- can limit grid current when the tube is driven into the positive grid region, which helps in preventing "blocking" distortion

In order to take advantage of the parasitic suppression benefits of these grid resistors, they must be placed as close as possible to the socket pin of the tube, preferably soldered directly to the pin with a very short lead.

The power tube grid resistor value typically varies from as low as 1.5K to as high as 10K.

Input Grid Resistors

We have supplied 68K per channel but in some case you may want to increase the drive to V1, in such a case, make these each 33K

More Tips for fine tuning your amp

These are very simplistic modifications you can do to your amp, let your ears be your guide:

- Change coupling caps; changing to smaller values reduces bass, changing to larger values adds more bass. Reducing the value of coupling caps can help eliminate "flabby" bass syndrome.
- Change cathode bypass caps. Adding a cathode bypass cap to a stage that doesn't have one will let the stage have more gain. Just like coupling caps, making the value larger adds bass - generally 25uF allows almost all bass through, .68uF are used in some Marshalls for a more midrange boost and 1uF and 5uF are used in some high end fusion type amps. Again, smaller values can help reduce "flabby" bass.
- Change cathode resistors - larger values reduce gain, smaller values give more gain. A "trick" is to connect a 5K+pot wired as a variable resistor instead of the standard cathode resistor - now you can turn the pot and dial in the perfect tone. After dialing the sound, remove the resistor and pot and measure it. Substitute the nearest standard value resistor in place of the pot plus a resistor.
- Add grid stopping resistors to help tame oscillation. If you have oscillation with your amp, you can sometimes help it by installing grid stopping resistors. The grid stoppers can also subtly roll off high end as well.
- Add high frequency roll off caps in parallel with the plate resistor. This is sometimes used to "mellow" out a stage (reduces highs).
- Adjust the grid leak resistor. Reduce the value to attenuate the signal into the stage to control the gain.
- Replace all plate resistors with metal film types. This can help reduce hiss..

How to read Resistor Color Codes

First the code

Black	Brown	Red	Orange	Yellow	Green	Blue	Violet	Gray	White
0	1	2	3	4	5	6	7	8	9

How to read the Color Code



First find the tolerance band, it will typically be gold (5%) and sometimes silver (10%).

Starting from the other end, identify the first band - write down the number associated with that color; in this case Blue is 6.

Now 'read' the next color, here it is red so write down a '2' next to the six. (you should have '62' so far.)

Now read the third or 'multiplier' band and write down that number of zeros.

In this example it is two so we get '6200' or '6,200'. If the 'multiplier' band is Black (for zero) don't write any zeros down.

If the 'multiplier' band is Gold move the decimal point one to the left. If the 'multiplier' band is Silver move the decimal point two places to the left. If the resistor has one more band past the tolerance band it is

a quality band.

Read the number as the '% Failure rate per 1000 hour'. This is rated assuming full wattage being applied to the resistors. (To get better failure rates, resistors are typically specified to have twice the needed wattage dissipation that the circuit produces.) 1% resistors have three bands to read digits to the left of the multiplier. They have a different temperature coefficient in order to provide the 1% tolerance. At 1%, most error is in the temperature coefficient - i.e. 20ppm.

How to read Capacitor Codes

Large capacitor have the value printed plainly on them, such as 10.uF (Ten Micro Farads) but smaller disk types along with plastic film types often have just 2 or three numbers on them?

First, most will have three numbers, but sometimes there are just two numbers. These are read as Pico-Farads. An example: 47 printed on a small disk can be assumed to be 47 Pico-Farads (or 47 puFf as some like to say)

Now, what about the three numbers? It is somewhat similar to the resistor code. The first two are the 1st and 2nd significant digits and the third is a multiplier code. Most of the time the last digit tells you how many zeros to write after the first two digits, but the standard (EIA standard RS-198) has a couple of curves that you probably will never see. But just to be complete here it is in a table.

milli, micro, nano, pico

1 mili Farad (or any other unit) is 1/1,000th or .001 times the unit. (10^{-3})

1 micro = 1/1,000,000 or 0.000 001 times the unit (10^{-6})

1 nano = 1/1,000,000,000 or 0.000 000 001 times the unit (10^{-9})

1 pico = 1/1,000,000,000,000 or 0.000 000 000 001 times the unit (10^{-12})

Table 1 Digit multipliers	
Third digit	Multiplier (this times the first two digits gives you the value in Pico-Farads)
0	1
1	10
2	100
3	1,000
4	10,000
5	100,000
6 not used	
7 not used	
8	.01
9	.1

Now for an example: A capacitor marked 104 is 10 with 4 more zeros or 100,000pF which is otherwise referred to as a 0.1 μ F capacitor.

Most kit builders don't need to go further but there is sometimes a tolerance code given by a single letter.

So a 103J is a 10,000 pF with +/-5% tolerance

Typical Capacitor Markings			
Code	pf	nf	μ F
510	51	0.051	0.0000510
181	180	0.18	0.00018
501	500	0.5	0.0005
472	4700	4.7	0.0047
103	10000	10	0.01
123	12000	12	0.012
203	20000	20	0.02
223	22000	22	0.022
104	100000	100	0.1
684	680000	680	0.68

Table 2 Letter tolerance code	
Letter symbol	Tolerance of capacitor
B +/-	0.10%
C +/-	0.25%
D +/-	0.5%
E +/-	0.5%
F +/-	1%
G +/-	2%
H +/-	3%
J +/-	5%
K +/-	10%

M +/	20%
N +/	0.05%
P +100%	0%
Z +80%	20%

FAQ

NOTE: B+ stands Battery Plus == B+ and came from the old days of tubes. B+ is measured at the intersection of the rectifier DC output and the first filter cap.

Q: The pictures show the power and standby switches as "top and bottom" on the back of the switch, the layout shows them as "front and back" and I have back mounted "left and right". Does it make a difference as to what orientation I choose to make sure the switch operate correctly, i.e. on is on and off is off?

A: It does make a difference as to what orientation you choose to make sure the switches operate correctly. Put a switch in any position and measure the resistance across two terminals. "ON" is where resistance is zero. Then rotate the switch so that DOWN is ON (UK style).

Q: I assume that the shield is only attached to the pot; it is NOT connected to the tube socket?

A: Yes. Do not connect the shield at both ends on the volume pot OR input cables.

Q: The wire looks to be two basic sizes, "thin" and "thick". From the pictures, it looks like the "thin" is used for the pot wiring and the "thick" is for the tube sockets. Is this correct?

A: Use 22 gauge solid for hook up to tubes;

Use 22 gauge, twisted tightly for tube heater wiring;

Use 22 gauge solid/stranded for hook up to pots/front panel; and

Use 18 gauge, stranded, 600v for power supply hook up - to transformers, rectifier, standby etc.

Tip: Re-use cut-offs from the transformers for power supply hook up.

Q: What should I use for the jumper wires on the back of the eyelet board?

A: Use the provided solid 22 ga or the stranded supplied for jumpers, it is not critical.

Q: For the input jacks:

a): I should be using the shielded wire which is the thick gray/black wire that you supplied about 3' of. Does the shield braid from both lines go to the common tip lug on

the lower jack while the core line goes to the individual tip lugs on both jacks? I want to make sure I am interpreting the drawing correctly.

b). The other end of the shield does NOT get connected to the tag strip at V1, correct?

c). Each pair of input jacks gets only one resistor, correct? Can I lace one lead of the resistor through both jacks for the connection?

A: Take a look at the drawing of the input jacks. That should help you out. Use the shielded wire which is the heavy grey/black wire. The core goes to the hot. At the other end, the shield does NOT get connected to the tag strip at V1.

Q: Do you need use both of the fiber shoulder washers when mounting the input jacks?

A: Yes, we recommend that you do. Not required for the output jacks

Q: Is there hardware provided for the grounding? Screws, star washers, nuts, etc.?

A: Yes, these should be in the kit.

Note: The power grounds should not go the transformer mount as there is a separate hole to mount the grounding points.

Q: Is it easier to wire the pots up outside of the chassis on a cardboard with the pots spaced correctly, or can it be done easily in the chassis?

A: You can wire them in place, it's not too difficult, but I would wire the input jacks outside of the chassis with the approximate spacing to fit the panel.

TIP: It is easy to solder up the input jacks by putting them "inside out". Use a set of jack locations to the right of the normal channel and mount the jacks in their final orientation, but mounted outside of the chassis with the mounting screw inside the chassis. This keeps the orientation and spacing correct and gives you me a lot of room to solder the resistor, jumpers grounding wire and shielded wires. Then, when done, remove the completed jacks, mount them correctly inside the chassis and tighten up the mounting screws and solder up the other end of the shielded wires to the tag strips at V1.

TIP: More, larger format, colour pictures and the schematic & layout that are helpful in the build are posted on the Trinity Forum & 18 Watt forum. Right click on them to download if you want print in large, colour format.

Schematic: trinityamps.com Forum Index -> Resources

TIP: Flatten or remove the locating tabs on the pots so that they tighten properly on the chassis.

TIP: Sometimes carbon comp resistors are hard to decode the colours. It is a good idea to measure the resistances of these parts before assembly.

TIP: Use insulation tubes from the wiring on the resistor / cap leads around the tubes and pots by using longer pieces of insulation stripped from the supplied 22 or 20 ga wire.

TIP: There is no bleed resistor in the Deluxe. You don't need to worry about this unless you are going to poke around inside immediately after it's shutdown.

For safety, unplug the amp, then turn on the stand-by switch for a minute to help drain the caps. If you want to check them, measure B+ after you've done that. If there is still high voltage there, drain it again.

TIP: Heater Wires: Stranded wire is very hard to twist tightly. Stranded or solid doesn't make much difference. Solid wire stays in place better once it's positioned and a bit easier to feed through holes. If they aren't well twisted make sure they are tight against the chassis. You can use 22 ga solid for heaters. It is rated for more than 5A anyway.

Triton Bill Of Materials (BOM)

DESCRIPTION	QTY	CHECK
TRITON KIT WITH TRANSFORMER SET, CHASSIS, PANEL		
TRITON RESISTORS	1	
METAL OXIDE RESISTORS 510 OHMS 5% TOL	1	
WIREWOUND RESISTORS - THROUGH HOLE 560 OHMS 5% TOL	1	
WIREWOUND RESISTORS - THROUGH HOLE 750 OHMS 5% TOL	1	
RESISTORS - 2 WATT METAL OXIDE POWER 24 KO	1	
CARBON FILM RESISTORS- THROUGH HOLE 68K OHMS 0.05	2	
METAL OXIDE RESISTORS 220K OHMS 5% TOL	1	
CARBON FILM RESISTORS- THROUGH HOLE 270K OHMS 5%	1	
CARBON FILM RESISTORS- THROUGH HOLE 1M OHMS 5%	1	
CARBON FILM RESISTORS- THROUGH HOLE 2M OHMS 0.05	1	
CARBON FILM RESISTORS- THROUGH HOLE 6.8M OHMS 5%	1	
TRITON CAPACITORS	1	
CAPACITOR - 500V SILVER MICA ± 5% CAPACITANCE: 500 PF	1	
CAPACITOR - MALLORY 630V 150S AXIAL LEAD CAPACITANCE: .0047 UF	1	
CAPACITOR - 600V 716P SERIES POLYPROPYLENE CAPACITANCE: .022 UF	2	
CAPACITOR - 600V 716P SERIES POLYPROPYLENE CAPACITANCE: .047 UF	1	
CAPACITOR - 475V AXIAL LEAD ELECTROLYTIC CAPACITANCE: 16 UF	3	
CAPACITOR - 50V AXIAL LEAD ELECTROLYTIC 25 µF	1	
TRITON POTENTIOMETERS	1	
POTENTIOMETER - ALPHA 1M AUDIO WITH SWITCH	1	
POTENTIOMETER 500K OHMS PLAIN SOLDER LUGS	1	
TRITON CHASSIS HARDWARE	1	
KNOB - CHICKEN HEAD SET SCREW COLOR: BLACK	2	
RECEPTACLE - AC WITH 5X20MM FUSE HOLDER	1	
FUSE - SLOW-BLOW 250V MINIATURE 5MM X 20MM 2 AMPS	1	
LAMP - FENDER STYLE PREMIUM PILOT ASSEMBLY	1	
JEWEL - FENDER STYLE COLOR: RED	1	
DIAL LAMP - #47 T-3-1/4 6.3V 0.15A BAYONET BASE	1	
SWITCH - CARLING MINI TOGGLE DPDT 2 POSITION	2	
GROMMETS & BUSHINGS GROMMETS & BUSHINGS SB 500-6 BLK	2	
TRITON SOCKET	1	
SOCKET - BELTON MICALEX 8 PIN OCTAL MIP	3	
TUBE CLIP - BELTON FOR OCTAL SOLD INDIVIDUALLY	3	
TRITON JACKS	1	
SCREWS & FASTENERS WSHR FBR 3/8" .625"	2	
SCREWS & FASTENERS SHOULDER WASHER 3/8"	2	
JACK - SWITCHCRAFT ¼" MONO 2-CONDUCTOR OPEN CIRCUIT	2	
JACK - SWITCHCRAFT 1/4" MONO 2-CONDUCTOR SHUNT TIP	2	

TRITON FASTENERS	1	
MACHINE SCREW PHILLIPS PAN HEAD 4-40X5/16 L	9	
HEX NUT EXT TOOTH LOCKWASHER 4-40	1	
TERMINALS TERMINALS LUG LOCKING MATTE TINNED#4	2	
MACHINE SCREW PHILLIPS PAN HEAD 6-32X3/8 L	5	
MACHINE SCREW PHILLIPS PAN HEAD 6-32X1/2 L	4	
STANDOFFS & SPACERS .250 STD SPACER	4	
INTERNAL TOOTH LOCK WASHER #6 CHROME	4	
HEX NUT EXT TOOTH LOCKWASHER 6-32	9	
TERMINALS TERMINALS LUG LOCKING MATTE TINNED#6	2	
MACHINE SCREW PHILLIPS PAN HEAD 8-32X3/8 L	5	
HEX NUT EXT TOOTH LOCKWASHER 8-32	5	
TERMINALS TERMINALS LUG LOCKING MATTE TINNED#8	1	
MACHINE SCREW PHILLIPS TRUSS HEAD 10-32X1-1/4 L	2	
HEX NUT EXT TOOTH LOCKWASHER 10-32	2	
SAE FLAT WASHER #10	2	
TRITON WIRE	1	
22 GUAGE SOLID CORE WIRE (VARIOUS COLOURS)	10	
22 GAUGE TWISTED PAIR RED/BLACK	2	
BELDEN RG174/U COAXIAL CABLE	11	
18 GUAGE STRANDED WIRE BLACK	18	
18 GUAGE STRANDED WIRE WHITE	18	
HEAT SHRINK TUBING 1MM	4	
HEAT SHRINK TUBING 3MM	4	
HEAT SHRINK TUBING 6MM	2	
CABLE TIE 4 IN BLACK 18 LBS	6	
TRITON VACUUM TUBE SET	1	
VACUUM TUBE - 5Y3 S JJ ELECTRONICS RECTIFIER	1	
VACUUM TUBE - 6V6 JJ ELECTRONICS	1	
VACUUM TUBE - 6SJ7 PENTODE SHARP CUT-OFF	1	
CHASSIS TRITON CHROME .048 MIRROR SST	1	
TRITON EYELET BOARD	1	
CORD - POWER 18 AWG 3 CONDUCTOR DETACHABLE BLACK IEC LENGTH: 8 FEET	1	
TRANSFORMER SINGLE ENDED OT 3.5/4K	1	
TRANSFORMER PT 630V CT @ 100mA 120/230/240 TRITON	1	

Some of the parts contained in this kit are subject to availability. Some may be used to ship transformers in place.

Trinity Amps Inc. reserves the right to change or substitute any and all of the parts contained in this amplifier kit without notification. Part substitutions made by Trinity Amps are guaranteed not to affect the integrity or operation of your amplifier.

Trinity Amps Schematics and Layouts