

D

D

C

C

B

B

A

A

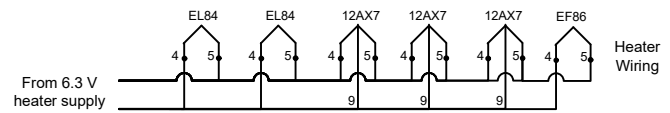
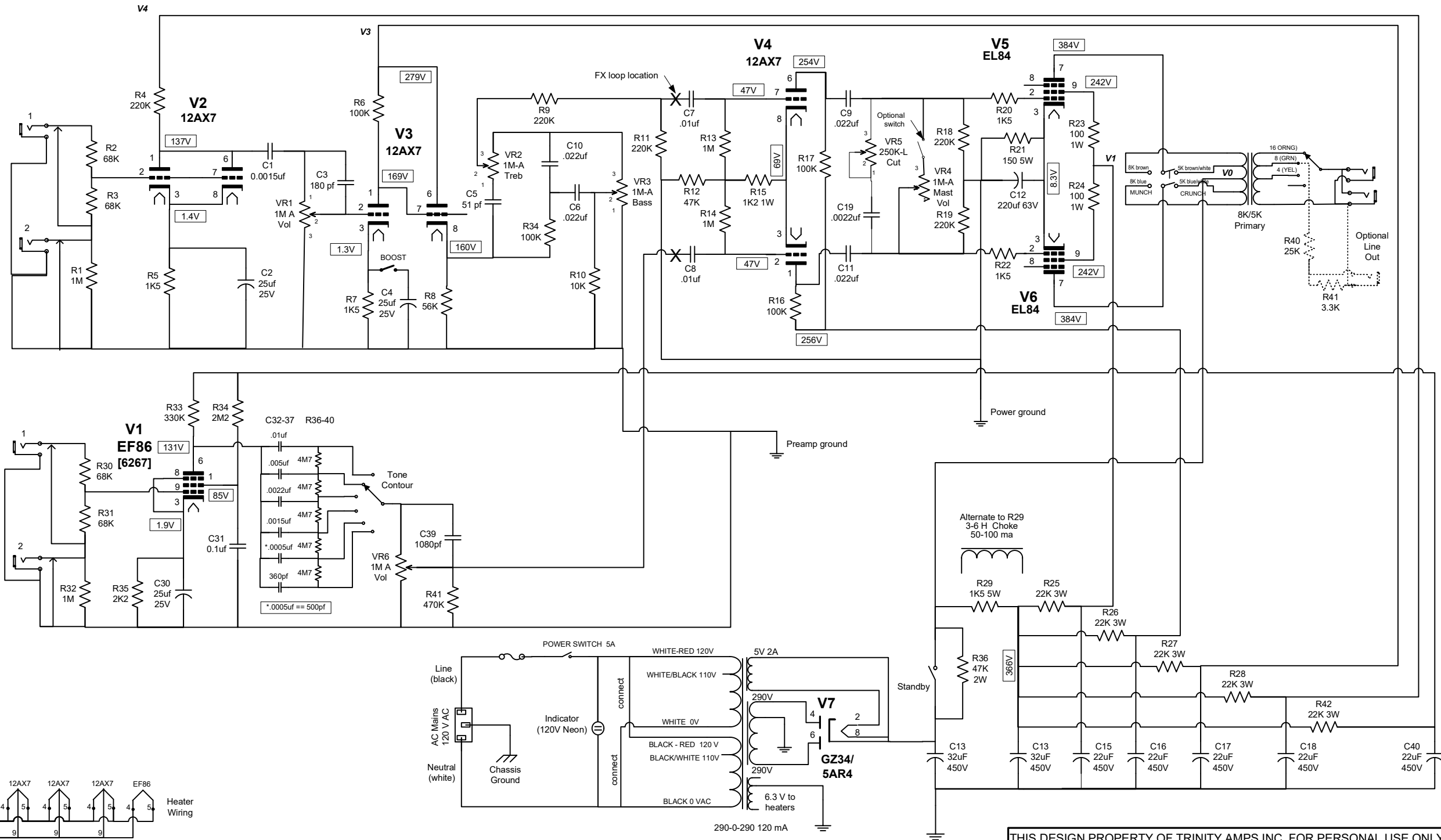

Notes

1. Resistors - 1 watt carbon film except as noted and input 68K & 1M which are Metal Film
2. 0.01 & 0.02 Coupling Caps Mallory 150 series
3. Metal oxide resistors throughout power supply & plates & on the P-tube screens.

TWEAKS: R33 220K & R34 1M to reduce stiffness and add compression on EF86; C1 .005 for thicker tone; R15 820R for hotter PI & to reduce brittleness on extreme OD; R12 56K for less PI drive; R10 50K pot to adjust mid; C19 to .0047 more cut.

1. First release April 5, 2007
2. Oct 5/07 - added optional MV switch
3. Dec07 - corrected EF-86 connections
4. 22Jan08 - cut control 250K-L
5. 25Jun13 - EF86 plate voltage updated
6. 13Feb14 - Tweak notes added.
7. 15May14 - Crunch-Munch details added
8. 8Jan16 - contour 5.1M-4.7M; added note
9. 29Nov16 - R21 Bias resistor changed to 150 5W
10. 7Jul18 - New Power Transformer updated
11. 13Nov18 - Updated for 150R 5W
12. 21Dec18 corrected PI LTP configuration

THIS DESIGN PROPERTY OF TRINITY AMPS INC. FOR PERSONAL USE ONLY

Trinity Amps

TC15

SIZE	FSCM NO	DWG NO	REV
SCALE	1 : 1	SHEET	1 OF 40

